

KQG

SERIES TILTING-TYPE BALL SANDWICH POT

系列可倾式球形夹层锅

The pot consists of pot body, brace, worm and worm wheel. The pot body can rotate within 180 degree. The equipment adopts open-top concentration, which is mainly used to boil and concentrate liquid materials of pharmacy, food, chemical engineering and light industry. The part contacting materials adopts stainless steel SUS304. This equipment is anti-corrosion and durable, it is in accordance with GMP medical system. Mixing device can be added at users' request.

This equipment has batching which mixes the structure and concentrate the device, is used extensively. This equipment and supplies are kept in touch with and adopt the stainless steel to make partly, durable in use, And accord with GMP standard request.

可倾式夹层锅由锅体、支架、蜗轮、蜗杆等部件组成，锅体可作180度以内的转动，本设备为敞口式浓缩，主要用于制药、食品、化工、轻工等行业对料液的煎煮和浓缩，该设备与物料接触部分为不锈钢SUS304，具有较好的耐腐蚀性能，经久耐用，符合GMP医药标准，同时亦可根据用户要求，可增加搅拌装置。

本设备是带有搅拌结构的配料与浓缩装置，应用广泛。本设备与物料接触部分均采用不锈钢制造，经久耐用，并符合GMP标准要求。

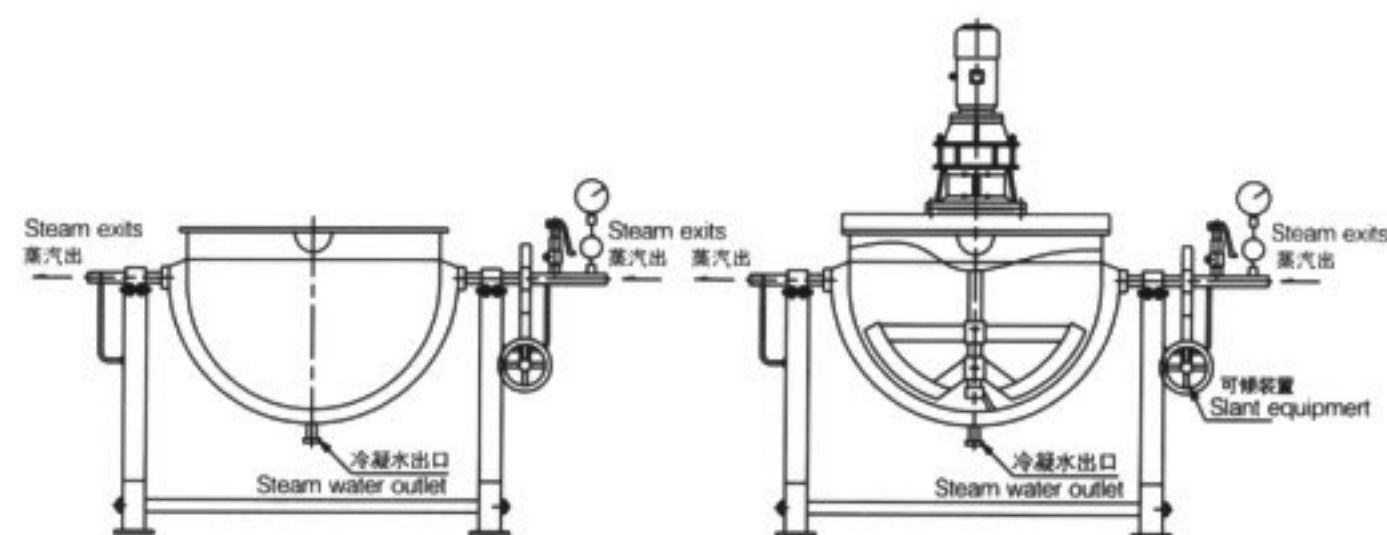

可倾式夹层锅 Tilting double-layered cauldron
可倾式夹层锅(带搅拌) Tilting double-layered cauldron(with agitator)

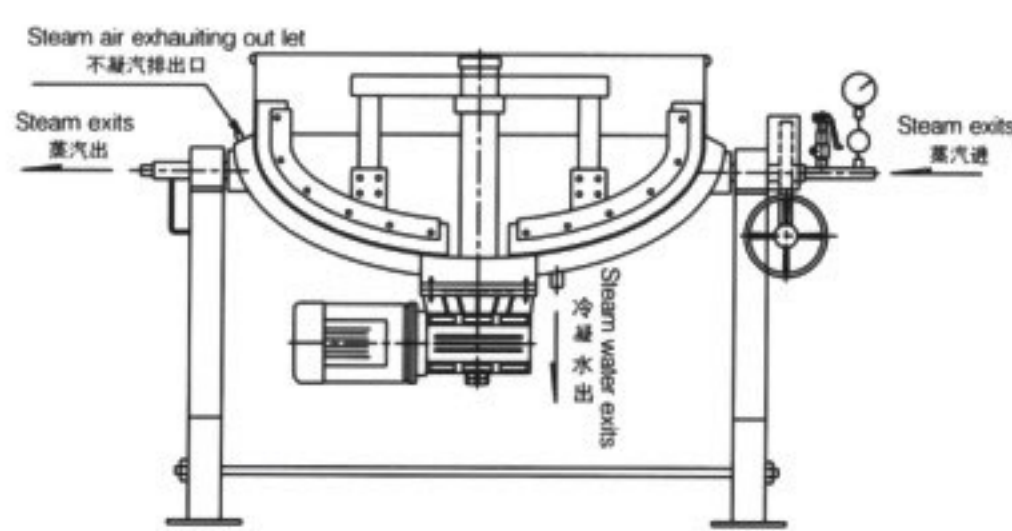

可倾式夹层锅(特殊型) Tilting double-layered cauldron(special type)



技术参数 Technology parameter

规格\型号	KQG50	KQG100	KQG150	KQG200	KQG300	KQG400	KQG500
设备容量(L)	50	100	150	200	300	400	500
夹套工作压力(MPa)				<0.2			
蒸发量(Kgh)	30	40	50	65	75	100	150
加热面积(m ²)	0.4	0.45	0.76	1.0	1.44	1.44	1.90
能耗(kg)	33	44	55	72	110	110	165
设备重量(Kg)	170	190	210	230	360	360	485
外型尺寸 长×宽×高(mm)	720×600 ×830	800×650 ×950	1350×660 ×1000	1400×700 ×1100	1500×850 ×1140	1500×850 ×1140	1600×900 ×1150